

Stabilisation of Wind Farm Integrated Power System by Using STATCOM/SMES

M. Amzad Hossain

Abstract— In this work, the STATCOM/SMES system with a voltage-source IGBT converter is modeled as a controllable energy source. The objective of the proposed STATCOM/SMES topology is to provide both active and reactive power, which can significantly decrease the voltage and power fluctuations of grid connected fixed speed wind farm. One major problem in wind generator output power smoothing is setting of the reference output power. Constant output power reference is not a good choice because there can be some cases where wind speed is very low and then sufficient power cannot be obtained. In that case, energy storage device can solve the problem but large energy storage capacity may be needed. Therefore, to generate output power reference STATCOM/SMES with wind power is modeled using a filter approach in which a Simple Moving Average (SMA) corresponds to the energy storage capacity. Thus the capacity of SMES can be small. Simulation results clearly show that the proposed STATCOM/SMES topology can smooth well the wind generator output power and also maintain the terminal voltage at rated level.

Index Terms— Wind Energy, Integrated Power, Fluctuations, Reference Power, SMA, STATCOM, SMES

1 INTRODUCTION

THE most important requirements during the operation of the electric power system is the operation security. This concept is related to the system capability of maintaining its operation in case of an unexpected failure of some of its components (e.g.: lines, generators, transformers, etc.). Hereof, it is derived the necessity of having available enough “short-term generation reserve” in order to preserve acceptable security levels. This reserve must be appropriately activated by means of the frequency control in order to keep the system frequency above the acceptable minimum level during the transient. Otherwise, serious problems could occur in the utility system. Nowadays, the new energy storage systems (ESS) are a feasible alternative to decrease the reserve power of generators. By using proper energy storage devices, excess energy may be stored to substitute the power reserve of generators during the action of the primary frequency control. In this sense, research in this field has been lately extended with the aim of incorporating power electronics devices into electric power systems. The goal pursued is to control the operation of the power system, a fact that clearly affects the operation security. In bulk power transmission systems, power electronics-based controllers are frequently called Flexible AC Transmission Systems (FACTS). Presently, these devices are a viable alternative as they allow to control voltages and currents of appropriate magnitude for electric power systems at an increasingly lower cost.

Voltage or current source inverter based FACTS devices such

transfer switch (SSTS) and unified power flow controller (UPFC) have been used for flexible power flow control, secure loading and damping of power system oscillation [1-3]. But FACTS/ESS, i.e., FACTS with energy storage system (ESS) have recently emerged as more promising devices for power system applications [4]. Of these superconducting magnetic energy storage systems (SMES), have received much attention among the researcher. The SMES is well known to be a system where energy is stored within a magnet that is capable of quickly releasing megawatt amounts of power. Thus SMES applications have been considered as new options to solve a variety of transmission, generation, and distribution system problems including improvement of voltage and angular stability, increasing power transfer capability of existing grids, damping sub synchronous oscillations, damping inter-area oscillations, load leveling etc. [5-6]. Using SMES devices substantially enhances the controllability and provides operation flexibility to a power system and is therefore a prospective option in building a FACTS.

The SMES system is combined with the voltage-source IGBT converter is capable of effectively controlling and near instantaneously injecting both active and reactive power into the power system. To evaluate the effectiveness of SMES systems with respect to power applications, different techniques have been used and many variants of mathematical description have been developed. In many papers, the eigen-value analysis, followed by digital simulation of the dynamics is applied. Usually, simplified device controls and small or middle size power system are studied. However, in practical applications it is necessary to evaluate the impact of SMES on electromechanical processes of large actual power system and to analyze the effectiveness of complex control schemes with their nonlinear elements and delays adequately represented. The current article proposes a model of a STATCOM/SMES and a control algorithm for this combined system to minimize voltage and power fluctuations of wind generator during random wind speed variations. Considering these viewpoints, the proposed control strategy is a very effective means of stabilizing

-
- M. Amzad Hossain is currently pursuing masters degree program in department of electrical and electronic Engineering in Rajshahi University of Engineering & Technology, Bangladesh. Presently he is working in department of electrical and electronic engineering in Jessore University of Science and Technology, Bangladesh, PH-+880171249844, E-mail: ma-hossain.eee@gmail.com. His research interests in renewable energy and power system stability.

as static var compensator (SVC), static synchronous compensator (STATCOM), dynamic voltage restorer (DVR), solid state

zation of wind generator as well as entire power system.

2 MODEL SYSTEM

Figure 1 shows the model system where one synchronous generator (SG) is connected to infinite bus through transformers and a double circuit transmission lines. The line parameters are numerically shown in the form of $R+jX$. One wind farm (WF) is connected with the network via a transformer and a short transmission line. A capacitor bank has been used at each wind generator terminal for reactive power compensation at steady state. The SMES unit is connected at the WF terminal bus. The AVR (Automatic Voltage Regulator) and GOV (Governor) control system models for the synchronous generator and the generator parameters are same as those used in [9].

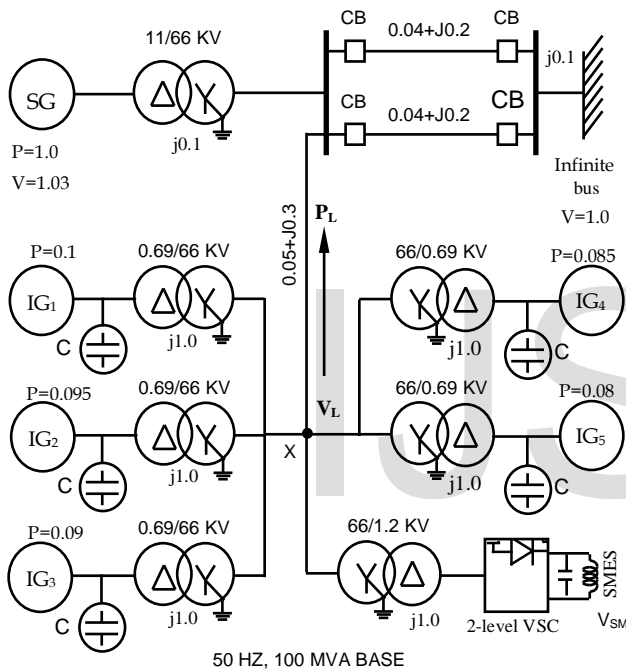

Fig. 1. Power system model with STATCOM/SMES

3 STATCOM/SMES TOPOLOGY

3.1 Integration of SMES system with STATCOM

In principle, a Static Synchronous Compensator or STATCOM is a shunt-connected device which injects reactive current into the AC system. This leading or lagging current, which can be controlled independently of the AC system voltage, is supplied through a power electronics-based variable voltage source. The STATCOM does not employ capacitor or reactor banks to produce reactive power as the Static Var Compensators (SVC) do. In the STATCOM, the capacitor is used to maintain a constant DC voltage in order to allow the operation of the voltage-source converter. A STATCOM controller with SMES is similar to an ideal synchronous machine which generates a balanced set of (three) sinusoidal voltages at the fundamental frequency, with controllable amplitude and phase angle. This ideal machine has no inertia, its response is practically instantaneous, it does not significantly alter the system

impedance, and it can internally generate reactive (both capacitive and inductive) power. Furthermore, it can exchange dynamically active power with the AC system if it is coupled to an appropriate energy source that can supply or absorb this power. A functional model of a STATCOM integrated with energy storage is shown in Figure 2. The basic component of the STATCOM is the voltage-source inverter (VSI) with semiconductor devices having turn-off capabilities (typically GTOs). It is also made up of a coupling step-up transformer, a DC capacitor, an interface device with the energy storage system and the control block of the STATCOM/SMES. This control block produces the switching signals for the VSI thyristors and the interface with the SMES.

3.2 PWM VSC Modeling

In this study, the well-known cascade control scheme with independent control of the active and reactive current was developed as shown in Figure 2 and Figure 3. The aim of the control is to maintain the magnitude of voltage at the wind farm terminal to be at the desired level, under abnormal condition. The DC link voltage (V_{dc}) is also kept constant at the rated value. Finally, the three-phase reference signals are compared with the triangular carrier wave signal in order to generate the switching signals for the IGBT-switched VSC. High switching frequencies can be used to improve the efficiency of the converter, without incurring significant switching losses. In the simulation, the switching frequency is chosen 1000 Hz. The DC link voltage is 2 kV. The SMES is coupled to the 66 kV line by a single step-down transformer (66/1.2 kV) with 0.2 pu leakage reactance (100 MVA Base). The DC link capacitor value is 50 mF [7].

3.3 Generation of Reference Line Power

Reference value of transmission line power P_L is determined by using Simple Moving Average (SMA). The n period SMA for period d is computed by SMA_d . If ten measurements, M_1 through M_{10} are available, the successive 4 period simple moving average, for example, are as follows:

$$SMA_4 = (M_4 + M_3 + M_2 + M_1) / 4 \quad (2)$$

$$SMA_5 = (M_5 + M_4 + M_3 + M_2) / 4 \quad (3)$$

$$SMA_{10} = (M_{10} + M_9 + M_8 + M_7) / 4 \quad (4)$$

It is not possible to compute a 4 period moving average until 4 periods data are available. That's why the first moving average in the above example is SMA_4 .

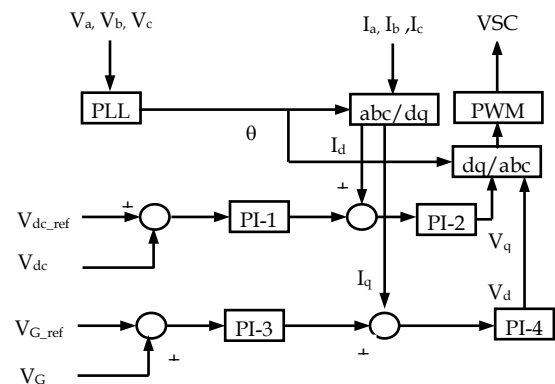

Fig 2. Control system of the VSC

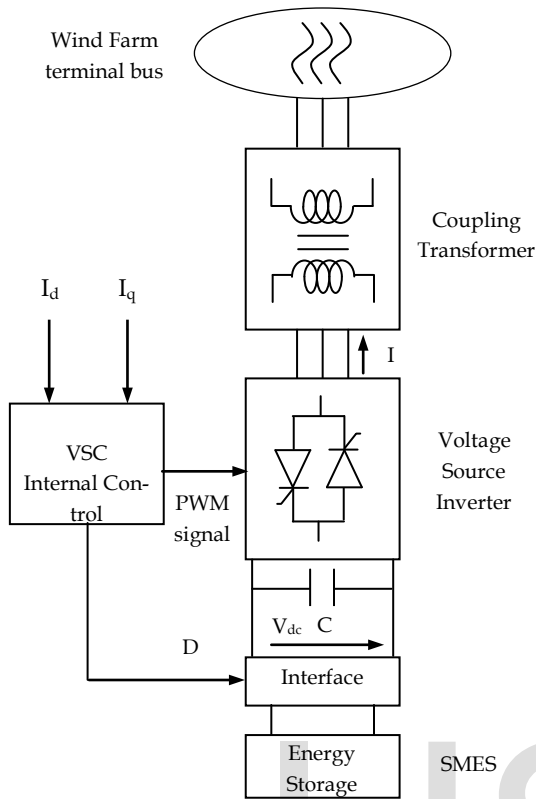

Fig. 3. Configuration of STATCOM/SMES topology

4 SIMULATION RESULTS

Real wind speed data shown in Figure 4, which was obtained in Hokkaido Island, Japan, is used in the simulation. The time step and simulation time have been chosen 0.00001sec and 600sec respectively. The simulations have been done by using PSCAD/EMTDC [10].

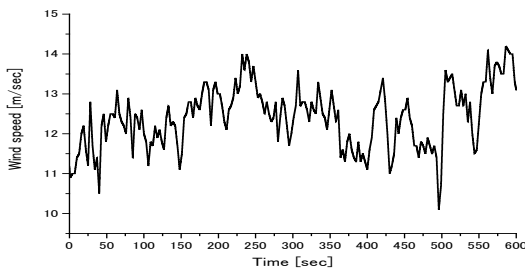

Fig. 4. Profile of real wind data

4.1 Conventional Pitch Controller without STATCOM/SMES Topology

In this case, the conventional pitch controller is used to control the IG output power at rated level when the wind speed is above the rated speed. Figure 5 and Figure 6 show the real power and terminal voltage responses of induction generator with using only the conventional pitch controller. The conventional pitch controller works only when wind speed is over the

rated speed [8]. It is seen that the conventional pitch controller cannot smooth well the wind generator output power and terminal voltage of induction generator.

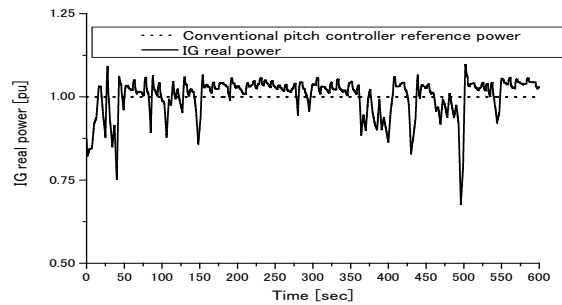

Fig. 5. Real power of IG with conventional pitch controller

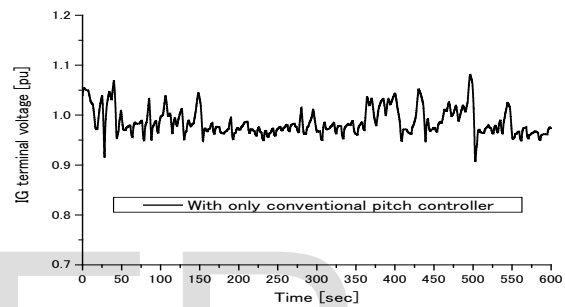

Fig. 6. Terminal voltage of IG with only conventional pitch controller

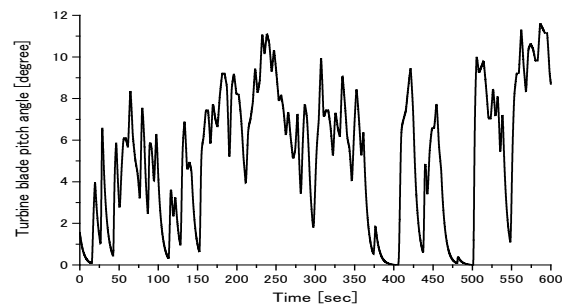

Fig. 7. Blade pitch angle of wind turbine

4.2 Conventional Pitch Controller with STATCOM/SMES Topology

In this case, the effectiveness of the control strategy of STATCOM/SMES is demonstrated. Figure 8 shows the responses of IG real power and reference line power with STATCOM/SMES. Figure 9 shows the line power and SMES real power. It is clear that STATCOM/SMES can smooth the line power well according to the reference line power. In Figure 10, the terminal voltage response of induction generator is presented when STATCOM/SMES is used. The STATCOM/SMES can provide necessary reactive power to maintain the constant voltage at wind generator terminal as shown

in Figure 10.

6 NOMENCLATURE

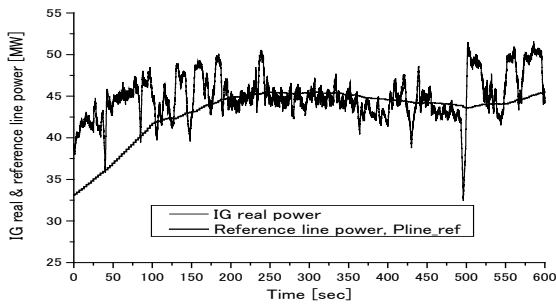

Fig. 8. Responses of IG real power and reference line power with STATCOM/SMES

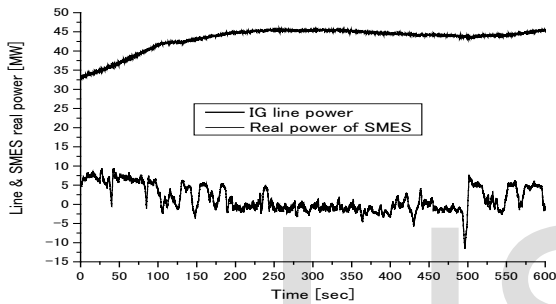

Fig. 9. Responses of IG line and SMES real power

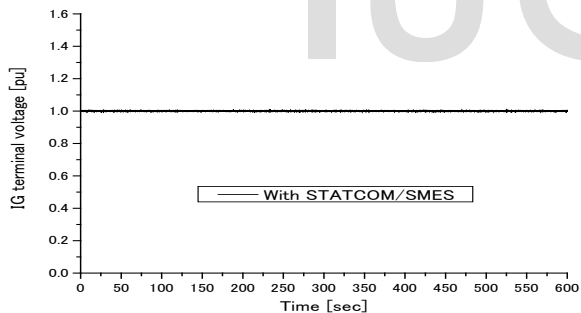

Fig. 10. Response of IG terminal voltage

5 CONCLUSION

In this study, the control scheme of STATCOM/SMES topology for wind power application is presented. As wind is fluctuating in nature, the output power and terminal voltage of wind generator also fluctuate randomly. The proposed control system can smooth the wind generator output power. Moreover, it can also maintain constant voltage magnitude at wind farm.

Symbol	Meaning	Unit
V_w	Wind velocity	(ms^{-1})
β	Blade pitch angle	(Deg)
V_L	Wind farm terminal voltage	(V)
V_{L_ref}	Wind farm terminal reference voltage	(V)
V_{dc}	Dc link voltage	(V)
V_{dc_ref}	Dc link reference voltage	(V)
P_G	Wind generator real power	(W)
Q_G	Wind generator reactive power	(VAR)
P_{ref}	Wind farm line reference real power	(W)

REFERENCES

- [1] Dr.L.Gyugyi, "Unified Power-Flow Control Concept for Flexible AC Transmission Systems," IEE Proc.-C, Vol.139, No.4, pp.323-331, 1992
- [2] Laszlo Gyugyi, "Dynamic Compensation of AC Transmission Lines By Solid-State Synchronous Voltage Sources," IEEE Trans. On Power Delivery, Vol.9, No.2, pp.904-911, 1994.
- [3] H.F.Wang, F.Li, and R.G.Cameron, "Facts Control Design Based on Power System Nonparametric Models," IEE Proc.-Generation, Transmission and Distribution Vol.146, No.5, pp.409-415, 1999.
- [4] L. Zhang, C. Shen, M. L. Crow, L. Dong, S. Pekarek, and S. Atcitty, "Performance Indices for the Dynamic Performance of FACTS and FACTS with Energy Storage," Electric Power Component and System, Vol.33, No.3, pp.299-314, March 2005.
- [5] Y. Mitani, K. Tsuji, and Y. Murakami, "Application of superconducting magnetic energy storage to improve power system dynamic performance", IEEE Trans. Power System., 3(1988), 1418-1425.
- [6] S. Banerjee, J. K. Chatterjee, and S. C. Tripathy, "Application of magnetic energy storage unit as load frequency stabilizer", IEEE Trans. on Energy Conversion, 5 (1990) 46-51.
- [7] R. Cardenas, R. Pena, G. Asher, and J. Clare, "Power smoothing in wind generation systems using a sensorless vector controlled induction Machine driving a flywheel," IEEE Trans. on Energy Conversion, Vol.19, Issue.1, pp. 206 - 216, 2004.
- [8] Anderson PM, Bose A. "Stability simulation of wind turbine systems", IEEE Transactions on Power Apparatus and Systems 1983; PAS-102: 3791-3795.
- [9] M. H. Ali, T. Murata, and J. Tamura "Wind Generator Stabilization by PWM voltage Source Converter and Chopper Controlled SMES" Conference Proc. of ICEM 2006 (International Conference on Electrical Machines), No. PTM1-8 (6 pages), 2006/9.
- [10] PSCAD/EMTDC Manual, Manitoba HVDC Research Center (1994).